

NOTE: MIRROR HEAD CONFIGURATION MAY VARY

LEFT HAND SIDE SHOWN
RIGHT HAND SIDE OPPOSITE

INSTALLATION INSTRUCTIONS

TOOLS REQUIRED: 3/16" HEX WRENCH,
WIRE CUTTERS,
CRIMPING TOOL

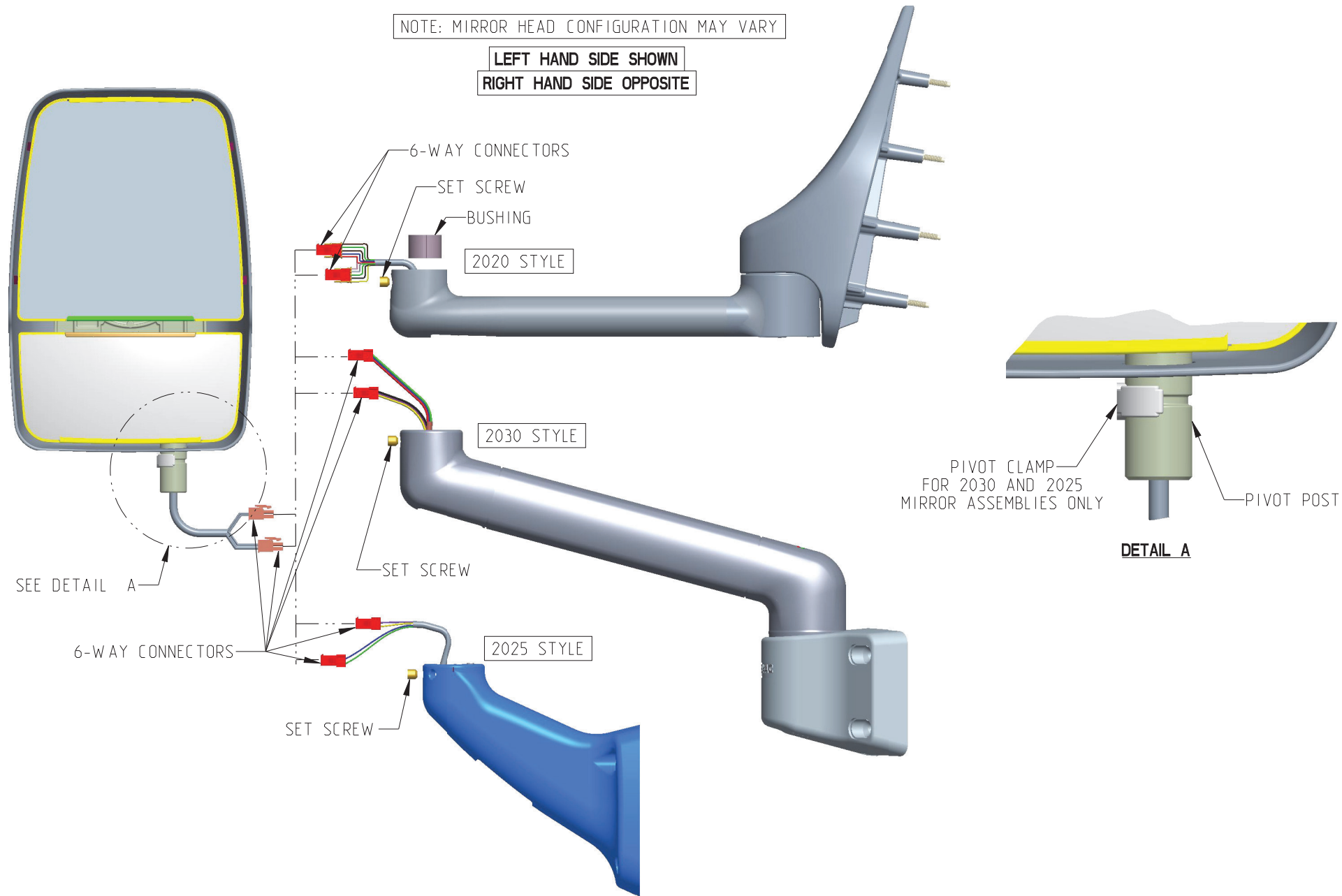

STEP #1 LOOSEN THE MIRROR HEAD SET SCREW.
STEP #2 CAREFULLY LIFT THE OLD MIRROR HEAD OUT OF THE MIRROR BASE OR MIRROR ARM AND CAREFULLY PULL THE WIRE HARNESS SLACK OUT OF THE MIRROR BASE OR MIRROR ARM.

NOTE #1: IF YOU SEE CONNECTORS CONTINUE TO STEP #3. IF YOU DO NOT SEE CONNECTORS SKIP TO STEP #6.

STEP #3: DISCONNECT OLD MIRROR HEAD 6-WAY CONNECTORS FROM ARM OR BASE CONNECTORS.
STEP #4: TO INSTALL REPLACEMENT HEAD, CONNECT THE 6-WAY CONNECTORS ON THE REPLACEMENT HEAD TO THE MATING CONNECTORS IN THE ARM OR BASE.

STEP #5: FOR 2020 MIRROR ASSY'S - INSERT THE BUSHING INSIDE THE MIRROR ARM AND SLIDE THE MIRROR HEAD POST INTO THE MIRROR ARM OR MIRROR BASE. CAREFUL NOT TO PINCH ANY WIRES.
FOR 2025 & 2030 MIRROR ASSY'S - INSTALL THE PIVOT CLAMP ON THE MIRROR HEAD POST AND SLIDE THE MIRROR HEAD POST INTO THE MIRROR ARM OR MIRROR BASE. CAREFUL NOT TO PINCH ANY WIRES.

SKIP TO STEP #15.

STEP #6: CUT WIRE HARNESS AS CLOSE AS POSSIBLE TO OLD MIRROR HEAD
STEP #7: CUT 6-WAY CONNECTORS OFF REPLACEMENT MIRROR HEAD LEAVING AS MUCH WIRE AS POSSIBLE. SEE VIEW B-B.

STEP #8: CUT OFF 2.50" OF THE GRAY JACKET FROM THE WIRE HARNESS COMING OUT OF THE MIRROR HEAD. SEE VIEW B-B.

STEP #9: CUT OFF 2.50" OF THE GRAY JACKET OFF THE WIRE HARNESS COMING OUT OF THE MIRROR ARM OR MIRROR BASE. SEE VIEW B-B.

STEP #10: STRIP 1/4" OFF OF INDIVIDUAL WIRES ON BOTH HARNESSES.

STEP #11: CONNECT REPLACEMENT MIRROR HEAD WIRES TO EXISTING MIRROR ARM OR MIRROR BASE WIRES USING BUTT CONNECTORS SUPPLIED WITH KIT.

STEP #12: MATCH WIRE COLORS IN REPLACEMENT MIRROR HEAD WITH WIRES IN MIRROR ARM OR MIRROR BASE AS SHOWN IN VIEW B-B. ENSURE BUTT CONNECTORS ARE CRIMPED SECURELY.

STEP #13: SLIDE THE MIRROR INTO THE MIRROR ARM OR MIRROR BASE. CAREFUL NOT TO PINCH ANY WIRES.

STEP #14: FOR 2020 MIRROR ASSY'S - INSERT THE BUSHING INSIDE THE MIRROR ARM AND SLIDE THE MIRROR HEAD POST INTO THE MIRROR ARM OR MIRROR BASE. CAREFUL NOT TO PINCH ANY WIRES.

FOR 2025 & 2030 MIRROR ASSY'S - INSTALL THE PIVOT CLAMP ON THE MIRROR HEAD POST AND SLIDE THE MIRROR HEAD POST INTO THE MIRROR ARM OR MIRROR BASE. CAREFUL NOT TO PINCH ANY WIRES.

STEP #15: PIVOT MIRROR HEAD INTO PROPER VIEWING POSITION AND TIGHTEN SET SCREW 95 ±5 IN-LBS.

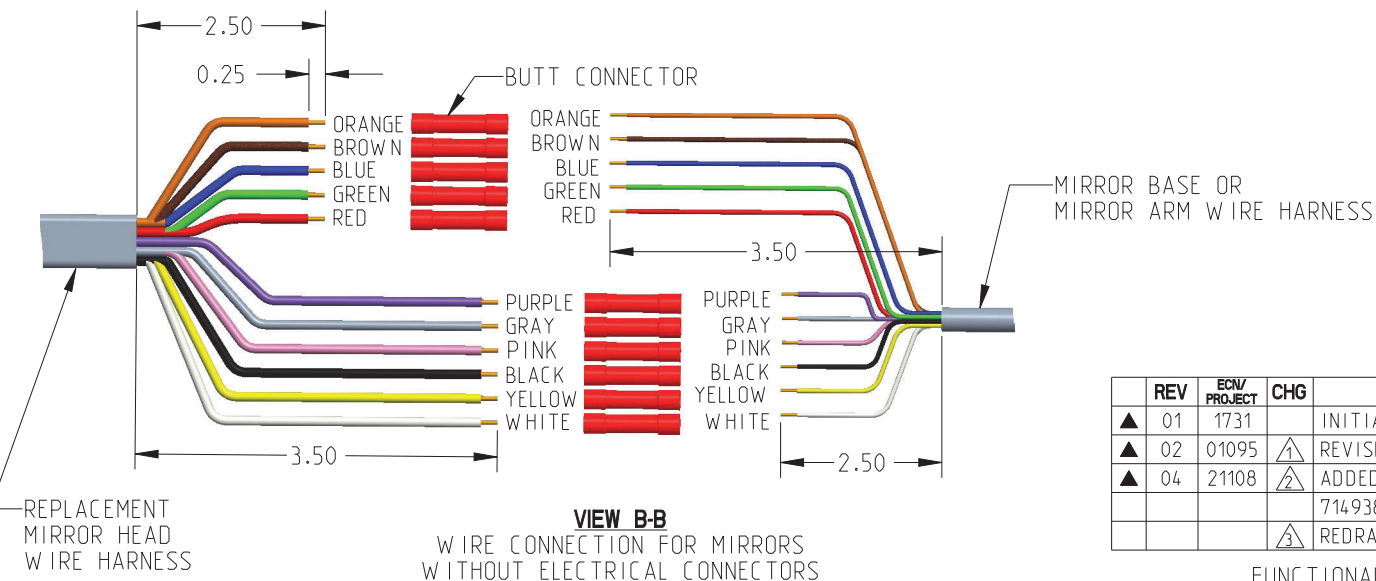

REV	ECN/PROJECT	CHG	CHANGE DESCRIPTION	DATE	CHG BY
▲ 01	1731		INITIAL RELEASE UNDER ECN#00478	12-07-00	MS
▲ 02	01095	1	REVISED STEP #3 WITH ELECTRIC PLUG	03-06-01	MS
▲ 04	21108	2	ADDED INFO FROM OBS INSTALLATION INSTRUCTION SHEET 7149842_01, 7149382_03, 7155062_02, 7149882_02 & 7145752_01.	03-01-23	PDG
		3	REDRAWN IN CREO. UPDATED FORMAT. MIGRATE TO WINDCHILL		

FUNCTIONAL REVISIONS: ALL REVISIONS WITH SOLID TRIANGLE ARE USABLE
Revisiones Funcionales: Todas las revisiones con Triangulos Solidos son utilizables

UNITS ARE inch [mm]		REV 04	
GEOMETRIC DIMENSIONING & TOLERANCING PER ASME Y14.5-2009 & Y14.51-2003		PRO	
MAJOR CHARACTERISTIC		SCALE: 0.200	DRAWN BY MS
DATE: 12-07-00		SHEET 1 OF 1	
INSTALLATION INSTRUCTION FOR REPLACEMENT MIRROR HEAD ASSEMBLY		DRAWING NO *7145812	

THIS CONCEPT & DRAWING IS THE PROPERTY OF VELVAC INC. AND SHALL NOT BE REPRODUCED, COPIED, DISCLOSED, OR USED FOR THE MANUFACTURE OR PROCUREMENT FROM SOURCES OTHER THAN VELVAC INC., WITHOUT WRITTEN PERMISSION FROM VELVAC, INC.